

maytronics

 ecoclear®

Single Speed Pool Pump

Installation & Operation Manual



Should the installer or owner be unfamiliar with the correct installation or operation of this type of equipment you should contact the distributor/manufacture for the correct advice before proceeding with the installation or operation of this product. The pump operator or owner must be provided with this owner's manual.

Manufactured by  PENTAIR

INTRODUCTION

The Industry Standard By Every Measure

We call it the Ecoclear® Single Speed Pool Pump® pump for good reason. This innovative hydraulic design moves water more efficiently and more quietly than competitive pumps. Under typical operating conditions, Ecoclear® Single Speed Pool Pump offers the highest water flow of any high performance pump — yet with the lowest electrical consumption. And, Ecoclear® Single Speed Pool Pump is designed to be a tireless workhorse. Its engineered thermoplastic housing withstands extreme heat and resists corrosion. The commercial grade motor frame has a rustproof, stainless steel motor shaft and sealed bearings that never need lubrication. Engineered to provide optimum performance in any size pool or pool and spa combination, Ecoclear® Single Speed Pool Pump is built to last a lifetime, and as a result, has become the industry's top seller for years.

- Ecoclear® Single Speed Pool Pump costs less to operate, because it uses less horsepower to produce required water flow.
- Specially-engineered design assures whisper-quiet operation as documented in rigorous ETL tests.
- Oversized strainer basket extends time between cleanings.
- See-through lid makes inspection fast and easy — engineered polymer remains clear and strong for years.
- User-friendly Cam and Ramp™ lid is easy to remove and quickly locks in place with a quarter-turn.

Quiet. Efficient. Durable.

The Maytronics Ecoclear® Single Speed Pool Pump manufactured by Pentair delivers maximum circulation efficiency at the lowest operating cost and long, troublefree life with minimal maintenance. Its legendary hydraulic design has been refined over 40 years for superior performance. No wonder more than 2 million Pentair pumps have been selected by pool professionals.

- Ecoclear® Single Speed Pool Pump costs less to operate, because it uses less horsepower to produce required water flow.
- Unique FunnelFlo™ diffuser and high-efficiency impeller maximize water flow and energy efficiency while minimizing turbulence and noise.
- Energy-efficient motor with commercial-grade frame, rustproof stainless steel shaft, and permanently lubricated, sealed bearings for long life.
- Available in single-speed and two-speed models.
- Ideal for pool and spa combinations and for operating in-floor cleaning systems.

TABLE OF CONTENTS

	Page
Model Data	4
Installation	5
Pressure Testing	6
Pump Mount	7
Teflon Taping Instructions	8
Fittings	8
Pool Outlets	8
Entrapment Protection	9
Testing and Certification	9
Outlets per Pump	9
Water Velocity	9
Electrical	10
Operation	11
Priming Pump	12
Service and Maintenance	13
Troubleshooting	14
Parts Breakdown	16

MODEL DATA

MODEL NAME	OUTPUT POWER		MAX TOTAL HEAD (M)
	(W)	(HP)	
EC-750-SS POOL PUMP	750	1	17
EC-1100-SS POOL PUMP	1100	1.5	18
EC-1500-SS POOL PUMP	1500	2	19

TECHNICAL INFORMATION

Inlet (Suction):(Suction): 2" BSP (female) thread on casing to suit 2" fittings with included barrel union adaptors to suit 50mm I.D. PVC pipe to AS/NZS 1477

Outlet (Discharge): 2" BSP (female) thread on casing to suit 2" fittings with included barrel union adaptors to suit 50mm I.D. PVC pipe to AS/NZS 1477

Max Working Pressure: 320 kPa

Water Temperature Range: 5°C – 38°C

IP Rating: IPX5

IElectrical Rating: 230-240V 50Hz single phase

Motor: Built in auto reset overload protection.
Flexible power supply cord 10Amp.

Recommended pH Range: 7.2 - 7.8 (Guide Only)

Maximum Ambient temperature: 55°C

INSTALLATION



ECOCLEAR® SINGLE SPEED POOL PUMP IS ELECTRICALLY CONNECTED. ENSURE THAT IT IS ISOLATED FROM ELECTRICAL SUPPLY DURING INSTALLATION AND ANY SUBSEQUENT SERVICE WORK.



A MEANS FOR DISCONNECTION MUST BE INCORPORATED IN THE FIXED WIRING, HAVING A CONTACT SEPARATION IN ALL POLES, IN ACCORDANCE WITH THE WIRING RULES.



THE PUMP SHOULD BE INSTALLED AND SERVICED BY A SUITABLY QUALIFIED PERSON IN ORDER TO AVOID HAZARD.



THESE INSTRUCTIONS ARE A GUIDE ONLY. SHOULD YOU THE INSTALLER OR OWNER OF THE PRODUCT BE UNFAMILIAR WITH THE CORRECT INSTALLATION OR OPERATION OF THIS PRODUCT YOU SHOULD CONTACT A SUITABLY QUALIFIED PERSON FOR ADVICE.



FREEZING CONDITIONS WILL DAMAGE THE UNIT, AS WATER EXPANDS AS IT FREEZES. ENSURE THAT ECOCLEAR® SINGLE SPEED POOL PUMP IS LOCATED SO THAT IT IS NOT PRONE TO FREEZING, OR ENSURE THAT THE PRODUCT IS DISCONNECTED AND DRIED OF WATER DURING COLD CONDITIONS.

INCORRECTLY INSTALLED OR TESTED EQUIPMENT MAY FAIL, CAUSING SEVERE INJURY OR PROPERTY DAMAGE.

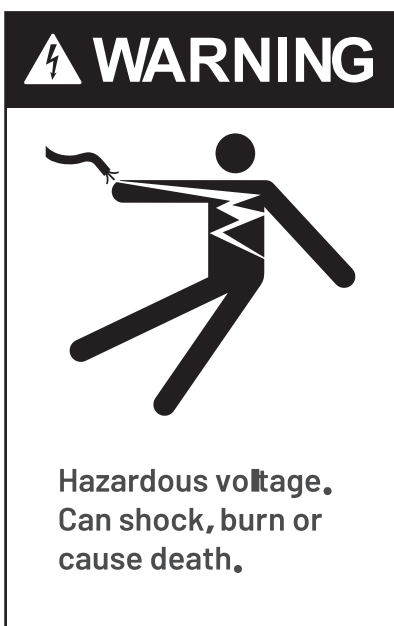

Read the following instructions in this owner's manual when installing and operating equipment. Have a trained pool professional perform all pressure tests.

1. Do not connect system to high pressure or mains water system.
2. Use equipment only in a swimming pool or spa pool installation.
3. Install pump with at least 2 hydraulically balanced main drains equipped with correctly installed, screw fastened, antientrapment certified covers according to local regulations.
4. Trapped air in system can cause explosion. Ensure all air is out of the system before operating or testing equipment.

PRESSURE TESTING

	<p>⚠ WARNING</p> <p>Hazardous pressure! Do not run pump against closed discharge.</p> <p>Release all pressure on system before working on any component.</p>
---	---

(Have a trained pool professional perform all pressure tests). Before pressure testing, make the following safety checks:

1. Check all clamps, bolts, lids, and system accessories prior to testing.
2. Release all air in system before testing.
3. Tighten trap lid to 4.1kg-m torque for testing.
4. Water pressure for test must be less than 170kPa (25 PSI)
5. Water temperature for test must be less than 38°C
6. Limit test to 24 hours. After test, visually check system to be sure it is ready for operation. Remove trap lid and retighten hand tight only.

⚠ WARNING

Fire and burn hazard. Modern motors run at high temperatures. To reduce risk of fire, do not allow leaves, debris, or foreign matter to collect around the pump motor. To avoid burns when handling the motor, let it cool for at least 20 minutes before trying to work on it. A thermal overload switch protects the motor from heat damage during operation.

Only qualified, licensed personnel should install pump. The electrical installation shall be in accordance with the national wiring rules (AS/NZS 3000) for class I, IP55 rated products. Refer to page 10 for Electrical Installation. Limit test to 24 hours. After test, visually check system to be sure it is ready for operation. Remove trap lid and retighten hand tight only.

PUMP MOUNT

The Industry Standard By Every Measure

Pump mount must:

1. Be located away from corrosive or flammable chemicals. Have enough ventilation to maintain air temperature at less than the maximum ambient temperature rating. If this pump is installed in an enclosure/pump house, the enclosure must have adequate ventilation (200sq.cm min, inlet & outlet) and air circulation to keep the temperature in the enclosure at or below the motor's rated ambient temperature whenever the pump is running. Keep rear of motor clear (150mm).

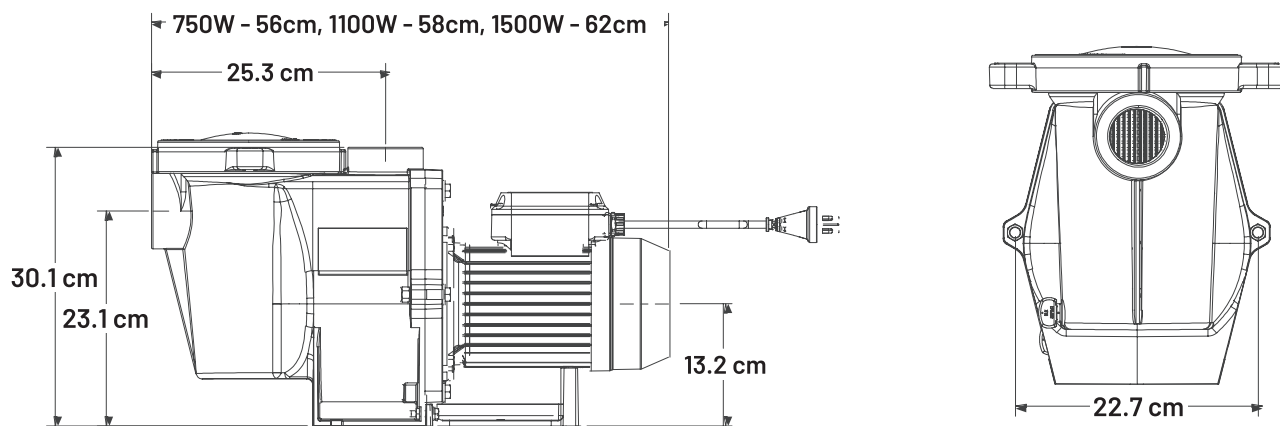

2. Be solid, level, rigid and vibration free. (To reduce vibration and pipe stress, bolt pump to mount). Fixing holes accept 12mm fasteners.
3. Allow pump suction inlet height to be as far below water level as possible.
4. Allow use of short, direct suction pipe (to reduce friction losses).
5. Allow for shut-off valves in suction and discharge piping.
6. Have adequate floor drainage to prevent flooding.
7. Be protected from excess moisture.
8. Allow adequate access for servicing pump and piping.

We recommend mounting the pump on a concrete platform for quietest performance.

⚠ WARNING

Use Teflon tape for making all threaded connections to the pump. DO NOT use pipe dope (glue) as this will cause stress fractures in the pump.

⚠ WARNING

Pump suction and discharge connections have moulded in thread stops. DO NOT screw pipe in beyond these stops.

⚠ WARNING

DO NOT use sealants which are incompatible with pipe fittings.

TEF ON TAPING INSTRUCTIONS

- Use only new or clean PVC pipe fittings.
- Wrap male pipe threads with a sufficient number of layers of Teflon tape.
- Cover entire thread portion.
- Do not overtighten or tighten past thread stop in pump port.
- If leaks occur, remove pipe, clean off old tape, wrap as previously with on to two additional layers of tape and remake the connection.

Piping

IMPORTANT

Support all piping connected to the pump.

- Use at least 2" (50mm) PVC pipe. Increase size if a long run is needed.
- To avoid stress on the pump, support both suction and discharge pipe independently.
- Place these supports as close to the pump as possible.
- To avoid a strain left by a gap at the last connection, start all piping at the pump and run pipe away from the pump.
- Never use a suction pipe smaller than pump suction connections.
- To avoid airlocking, slope suction pipe slightly upward toward the pump.
- Do not use an elbow near the suction port of the pump. Use a straight length of pipe into the suction port.

IMPORTANT

To prevent flooding when removing pump for service, all flooded suction systems must have shut-off valves in suction and discharge pipes.

Fittings

Fittings restrict flow; for best efficiency use fewest possible fittings. Avoid fittings which could cause an air trap.

Pool Outlets

Use only non-entrapping suction fitting or double suction conforming with the AS1926.3-2003 standard.

WARNING

Pump suction is hazardous and can trap and drown or disembowel bathers. Do not use or operate pump, pool or spa if a suction outlet cover is missing, broken, or loose. Follow the guidelines below for a pump installation which minimises risk to users or pools and spas.

Entrapment Protection

The pump suction system must provide protection against hazard of suction entrapment or hair entrapment/entanglement.

Testing and Certification

Suction outlet covers must have been tested by a nationally recognised testing laboratory and found to comply with the latest AS1926.3 standard or ASME/ANSI specification for Suction Fittings For Use in Swimming Pools, Spas, Hot Tubs, and Whirlpool Bathtub Applications.

Outlets Per Pump

Provide at least two hydraulically balanced main drains, with covers, for each swimming pool pump suction line. The centres of the main drains (suction fittings) must be at least 800mm apart. The system must be built so that it cannot operate with the pump drawing water from only one main drain (that is, there must be at least two main drains connected to the pump whenever it is running). However, if two main drains run into a single suction line, the single suction line may be equipped with a valve which will shut off both main drains from the pump. More than one pump can be connected to a single suction line as long as the requirements above are met.

Water Velocity

The maximum water velocity through any suction outlet must comply with the latest AS1926.3 Standard or ASME/ANSI Specification for Suction Fittings For Use in Swimming Pools, Spas, Hot Tubs, and Whirlpool Bathtub Applications.

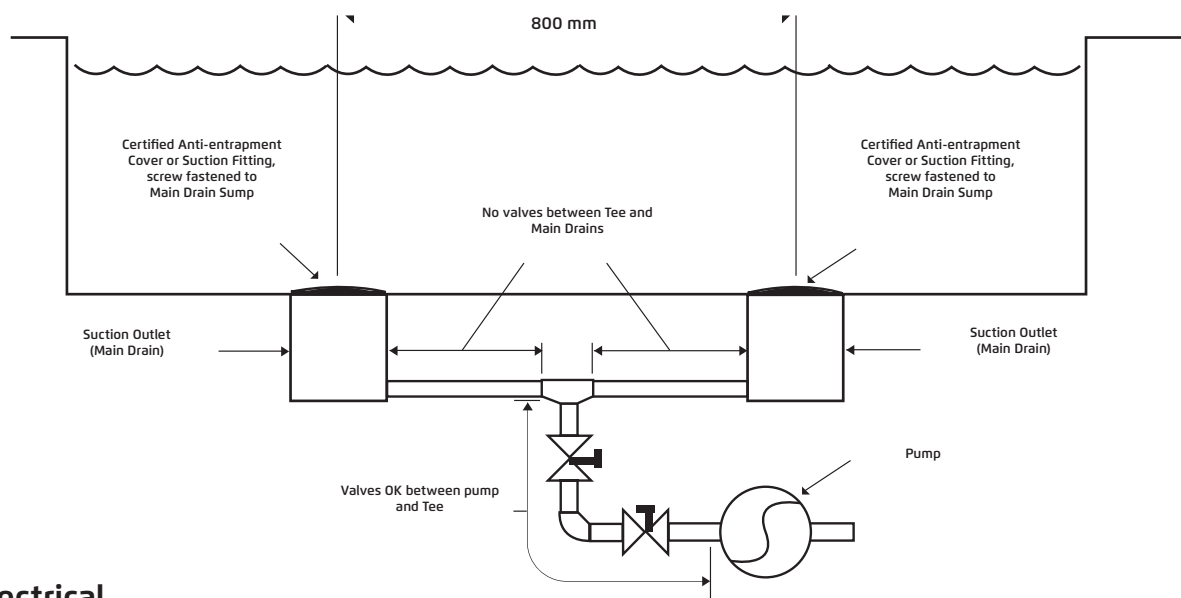

Electrical

Electrical installation shall be in accordance with the national wiring rules (AS/NZS 3000) taking into account its ratings (Class I, IPX5). The pump is supplied with a standard Australian 10 amp plug and 2 metres of cord. Select the correct Pool Zone for installation. Using the tapped hole terminal and tin plated copper lug connect the equipotential bonding conductor to the pump if required. The terminal is on the motor side of the flange. Remove paint from the terminal surface and use M5x12 zinc plated screw with lock washer or similar to secure the termination.

An RCD with maximum rated residual current of 30mA is required for the power supply to the pump. Additionally, if a suitable socket outlet is not available a weatherproof socket must be installed by an electrician in a suitable location. RCD tripping indicates an electrical problem. If RCD trips and will not reset have a qualified electrician inspect and repair electrical system.



Do not use extension leads as they are unsafe in and around the Pool Zone.

Incorrect voltage can cause fire or seriously damage pump and voids warranty.

Voltage at pump must not be more than 6% above or 10% below motor nameplate rated voltage or pump may overheat, causing overload tripping and reduced component life. If voltage is less than 90% or more than 106% of rated voltage when pump is running at full load, consult the power company.

To avoid dangerous or fatal electrical shock, turn OFF power to pump and remove plug from outlet before working on electrical connections.

The power supply cord has a type 'Y' attachment and if service is required to the power cord, it must be replaced with the specialised power cord assembly by Maytronics service agent or similarly qualified personnel in order to avoid a hazard. Warranty is void if unauthorised modifications are made to any component

OPERATION



THE PUMP OPERATOR OR OWNER MUST BE PROVIDED WITH THIS OWNER'S MANUAL. THIS MUST BE READ BEFORE OPERATION, AND FOLLOWED DURING OPERATION.



THE PUMP IS NOT INTENDED FOR USE BY YOUNG CHILDREN OR INFORM PERSONS WITHOUT SUPERVISION. YOUNG CHILDREN SHOULD BE SUPERVISED TO ENSURE THAT THEY DO NOT PLAY WITH THE PUMP.



NEVER RUN PUMP DRY. RUNNING PUMP DRY MAY DAMAGE SEALS, CAUSING LEAKAGE AND FLOODING. FILL PUMP WITH WATER BEFORE STARTING MOTOR.



IF PUMP HAS BEEN PRESSURE TESTED, ENSURE PRESSURE HAS BEEN RELEASED BEFORE REMOVING TRAP LID. DO NOT BLOCK PUMP SUCTION. TO DO SO WITH BODY MAY CAUSE SEVERE OR FATAL INJURY.



SMALL CHILDREN USING POOL MUST ALWAYS HAVE CLOSE ADULT SUPERVISION.



PUMP SUCTION IS HAZARDOUS AND CAN TRAP AND DROWN OR DISEMBOWEL BATHERS. DO NOT USE OR OPERATE PUMP, POOL/SPAS IF A SUCTION OUTLET COVER IS MISSING, BROKEN, OR LOOSE. FOLLOW THE GUIDELINES BELOW FOR A PUMP INSTALLATION WHICH MINIMISES RISK TO USERS OF POOL AND SPAS.



FIRE AND BURN HAZARD. MODERN MOTORS RUN AT HIGH TEMPERATURES. TO REDUCE THE RISK OF FIRE, DO NOT ALLOW LEAVES, DEBRIS, OR FOREIGN MATTER TO COLLECT AROUND THE PUMP MOTOR. TO AVOID BURNS WHEN HANDLING THE MOTOR, LET IT COOL FOR AT LEAST 20 MINUTES BEFORE TRYING TO WORK ON IT.

Before removing trap lid:

SWITCH OFF POWER SUPPLY to pump and unplug from outlet before proceeding.

CLOSE SHUT-OFF VALVES in suction and discharge pipes.

RELEASE ALL PRESSURE from pump and piping system.

NEVER tighten or loosen trap lid while pump is operating.

⚠ CAUTION

An automatic internal thermal overload switch protects the motor from heat damage during operation and if operated can restart without notice.

⚠ IMPORTANT

Maximum ambient temperature for motor operation must not exceed maximum ambient temperature range (See page 4). Switch the pump off at the controller or power point while ambient temperature exceeds maximum.

Priming Pump

Release all air from filter, pump and piping system: refer filter owner's manual. In a flooded suction system (water source higher than pump), pump will prime itself when suction and discharge valves are opened.

If pump is not in a flooded suction system, disconnect power supply to pump follow above instructions for removing trap lid; fill trap and pump with water.

Do not lubricate the trap lid o-ring. The original equipment O'ring contains a permanent internal lubricant.

If the o-ring needs replacement insist on genuine Maytronics service parts. Clean and inspect o-ring; reinstall on trap. Replace trap lid turn clockwise to tighten by hand only - no wrenches!

Pump should prime now. Priming time will depend on vertical height of suction lift and horizontal length of suction piping. The self-priming time range is 1 to 3 minutes for a height difference of 2 to 3 metres, under normal installation conditions. Normal conditions are understood to be: with suction having an internal diameter of DN 50mm, water temperature at 20°C, and 50Hz mains power supply.

Should the pump not prime, ensure that all valves are open, lint trap is clear of debris and suction and suction pipe end is submersed in water, and that there are no leaks in suction pipe. See troubleshooting guide.

⚠ DANGER



**Hazardous suction.
can trap hair or body
parts, causing severe
injury or death.**

**DO NOT BLOCK
SUCTION.**

SERVICE & MAINTENANCE



TO AVOID DANGEROUS OR FATAL ELECTRICAL SHOCK HAZARD, TURN OFF POWER TO MOTOR AND REMOVE PLUG FROM POWER OUTLET BEFORE WORKING ON PUMP OR MOTOR.

Routine Maintenance requires regular checking of the pump to ensure no water is leaking from joints whilst pump is operating and inspection/cleaning of trap basket. Debris or trash that collects in basket will choke off water flow through the pump.

Do not operate pump with trap basket missing or damaged.

Follow instructions below to clean trap:

1. Switch off power to pump, close valves in suction and discharge, and release all pressure from system before proceeding.
2. Remove trap cover (turn clockwise). If necessary, tap handles gently with a rubber mallet or use a board as a lever.
3. Remove strainer basket and clean. Ensure all holes in basket are clear, flush basket with water and replace in trap with large opening at pipe connection port (between ribs provided). If basket is replaced backwards, the cover will not fit on trap body. To clean transparent cover, use water and neutral soap only. Do not use solvents.
4. Clean and inspect lid o-ring; reinstall on trap.
5. Clean O'ring groove on trap body and replace cover. To help keep cover from sticking, tighten hand tight only.
6. Prime pump (refer priming instructions).

Pump Service

Pump should only be serviced by qualified personnel. For best results, use only genuine Maytronics service parts. Be sure to prime pump before starting.

Before removing clamp or trap cover

1. SWITCH OFF POWER to pump before proceeding.
2. CLOSE SHUT-OFF VALVES in suction and discharge pipes
3. RELEASE ALL PRESSURE from pump and piping system
4. NEVER tighten or loosen covers, valves, nuts or bolts while pump is operating!

TROUBLESHOOTING

No lubrication or regular maintenance is needed beyond reasonable care and periodic cleaning of strainer basket. When pump is not in use and there is a risk of frost, empty it completely through the drain plug. If shaft seal is worn or damaged consult your Maytronics authorised service agent.

SYMPTOM	CAUSE	REMEDY
<p>Low water pressure, low flow from pump. Filter start-up pressure low and water flow high</p>	<p>Suction leaks / lost prime.</p>	<p>Pump must be primed; make sure that the pump casing and strainer are full of water. Refer priming instructions.</p>
		<p>Check and tighten all connections. Teflon tape fittings.</p>
		<p>Make sure there are no leaks in suction piping.</p>
		<p>Make sure suction pipe inlet is well below the water level to prevent pump from sucking air.</p>
		<p>Suction lift of 3 to 6 metres will reduce performance. Suction lift of more than 6 metres will prevent pumping and cause pump to lose prime. In either instance, move the pump closer (vertically) to water source. Ensure that the suction pipe diameter is large enough.</p>
	<p>Low voltage.</p>	<p>Check voltage at motor terminals and at meter while pump is running - this check should be performed by a qualified electrician only. If voltage is low check for loose connections or consult your power company.</p>
	<p>Clogged pipe / strainer / impeller / filter system.</p>	<p>Ensure trap is not clogged with debris; clean basket and/ or filter.</p>
<p>Make sure that the impeller is not clogged. This should be checked by qualified personnel only.</p>		
		<p>Pump may be trying to push too high a column of water. If so, a higher pressure pump is required.</p>

SERVICE & MAINTENANCE

SYMPTOM	CAUSE	REMEDY
No water coming from pump (Pump is working).	Air ingress to system.	Prime the pump. Check that there are no air leaks in the suction piping or fittings. Ensure the strainer lid is airtight and fitted securely.
Pump does not work.	Motor thermal overload tripped	Check for required ventilation and cooling. If temperature is above the pump's maximum ambient, turn off pump until it cools down.
	No power at outlet.	Use another electrical appliance that is known to work to check power outlet.
	Blown fuse / Circuit breaker.	Check and call electrician if necessary.
	Motor burnt out due to voltage spike or flooded by water.	The motor may need replacing.
Pump running too slow.	Motor capacitor may be damaged.	Check line voltage; if less than 90% or more than 106% of rated voltage consult a licensed electrician.
Water leaking from between the casing and motor.	Casing bolts are not tightened sufficiently; worn mechanical seal requires replacing.	Switch off the power to the pump. Tighten the casing bolts or replace the mechanical seal as required.

Should problems persist, contact your nearest Maytronics Service Agent.

PARTS BREAKDOWN

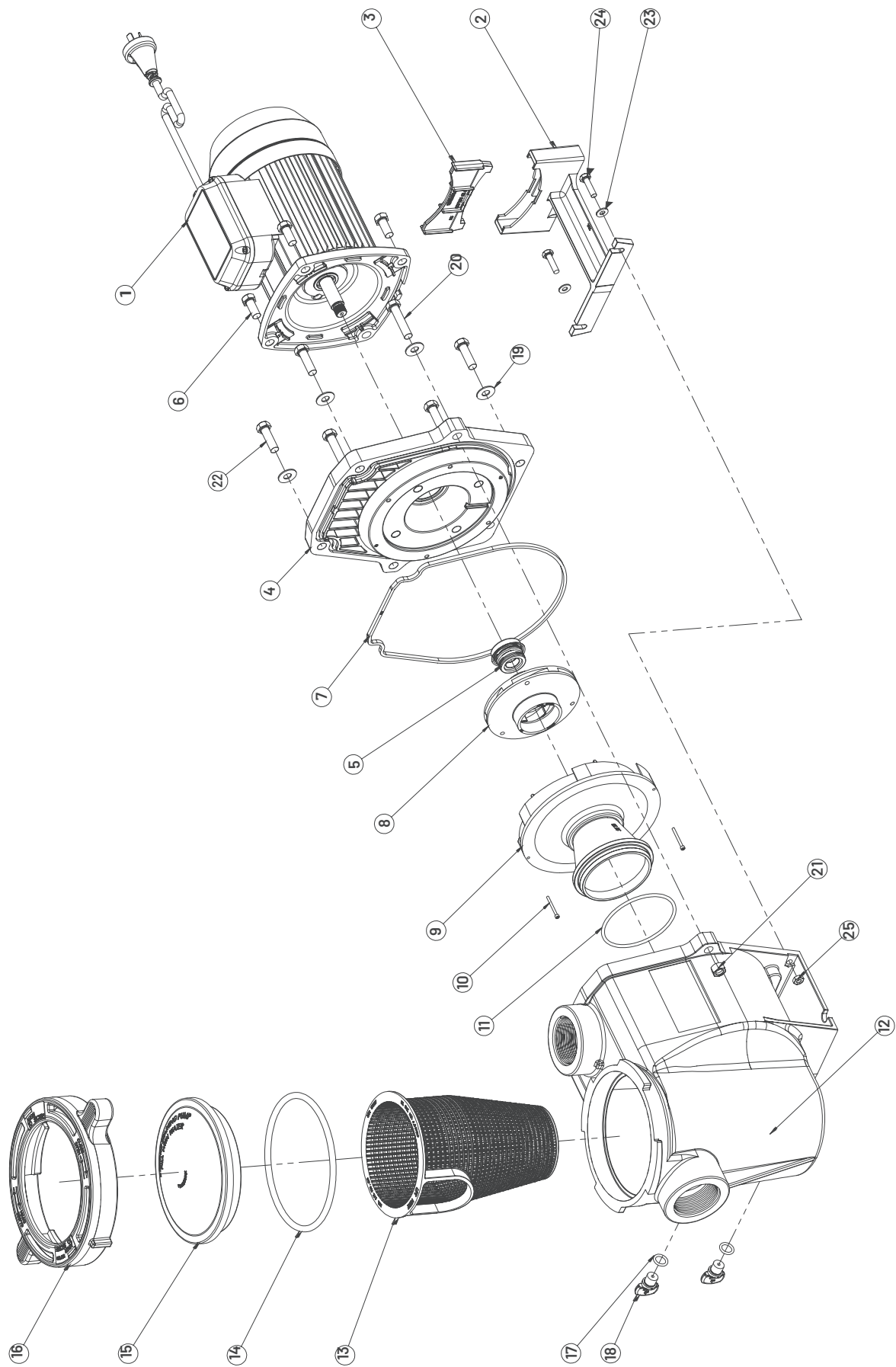

ITEM	DESCRIPTION	ITEM	DESCRIPTION
1	Motor, TEFC	14	O-ring, cover
2	Foot	15	Basket Cover
3	Foot insert	16	Clamp, Cam and Ramp
4	Seal Plate	17	O-ring, drain plug
5	Mechanical seal (PA-7)	18	Drain plug
6	Bolt, 3/8" x 7/8" Stainless Steel	19	Washer, 3/8" x 13/16" Stainless Steel
7	O-ring, seal plate	20	Bolt, 3/8" x 1.75" Stainless Steel
8	Impeller	21	Nut, 3/8" Stainless Steel
9	Diffuser	22	Bolt, 3/8" x 1.25" Stainless Steel
10	Set Screw, 4-40 x 1-1/8"	23	Washer, 1/4" x 5/8" Stainless Steel
11	O-ring, diffuser	24	Bolt, 1/4" x 1" Stainless Steel
12	Pump casing	25	Nut, 1/4" Stainless Steel
13	Basket		

Model and serial number of pumps must be given when ordering spare parts.

NOTES

NOTES

IMPORTANT

Please attach your sales invoice/docket here as proof of purchase should warranty service be required. Please do not return warranty form to Maytronics Australia – Retain for your records.

PURCHASED FROM:
PURCHASE DATE:
SERIAL NO:
MODEL NO:



Unit 2/91 Rudd Street, Oxley, QLD 4075 | Australia | 1300 693 657 | www.maytronics.com.au

Information contained here in remains the property of Maytronics Australia under Australian copyright law. Content may not be reproduced or transmitted without our prior written permission.

Disclaimer: Maytronics reserves the right to change product specifications and products details. Product images are for reference purposes only and may not represent the actual/current product.

©2022 Maytronics Australia Pty Ltd. All rights reserved.